

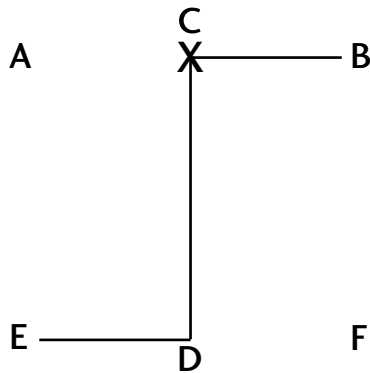

DO-SAN

(DO-SAN is the pseudonym of the patriot Ahn Chang-Ho (1876-1938) The 24 movements represent his entire life which he devoted to furthering the education of Korea and its independence movement. It has 24 movements).



The descriptions for this pattern assume that the student starts standing on line AB and facing D.

READY POSTURE: Parallel ready stance

1. Move the left foot to B, forming a left walking stance toward B while executing a high side block to B with the left outer forearm.
2. Execute a middle punch to B with the right fist while maintaining a left walking stance toward B.
3. Move the left foot on line AB, and then turn clockwise to form a right walking stance toward A while executing a high side block to A with the right outer forearm.
4. Execute a middle punch to A with the left fist while maintaining a right walking stance toward A.
5. Move the left foot to D, forming a right L-stance toward D while executing a middle guarding block to D with a knife-hand.
6. Move the right foot to D forming a right walking stance toward D while executing a middle thrust to D with the right straight fingertip.
7. Twist the right knife-hand together with the body counter clockwise until its palm faces downward and then move the left foot to D, turning counter clockwise to form a left walking stance toward D while executing a high side strike to D with the left back fist.
8. Move the right foot to D forming a right walking stance toward D while executing a high side strike to D with the right back fist.
9. Move the left foot to E, turning counter clockwise to form a left walking stance toward E while executing a high side block to E with the left outer forearm.

10. Execute a middle punch to E with the right fist while maintaining a left walking stance toward E.
 11. Move the left foot on line EF, and then turn clockwise to form a right walking stance toward F while executing a high side block to F with the right outer forearm.
 12. Execute a middle punch to F with the left fist while maintaining a right walking stance toward F.
 13. Move the left foot to CE forming a left walking stance toward CE, at the same time executing a high wedging block to CE with the outer forearm.
 14. Execute a middle front snap kick to CE with the right foot, keeping the position of the hands as they were in 13.
 15. Lower the right foot to CE forming a right walking stance toward CE while executing a middle punch to CE with the right fist.
 16. Execute a middle punch to CE with the left fist while maintaining a right walking stance toward CE. Perform 15 and 16 in a fast motion.
 17. Move the right foot to CF forming a right walking stance toward CF while executing a high wedging block to CF with the outer forearm.
 18. Execute a middle front snap kick to CF with the left foot, keeping the position of the hands as they were in 17.
 19. Lower the left foot to CF forming a left walking stance toward CF while executing a middle punch to CF with the left fist.
 20. Execute a middle punch to CF with the right fist while maintaining a left walking stance toward CF. Perform 19 and 20 in a fast motion.
 21. Move the left foot to C forming a left walking stance toward C, at the same time executing a rising block with the left forearm.
 22. Move the right foot to C forming a right walking stance toward C while executing a rising block with the right forearm.
 23. Move the left foot to B, turning counter clockwise to form a sitting stance toward D while executing a middle side strike to B with the left knife-hand.
 24. Bring the left foot to the right foot and then move the right foot to A forming a sitting stance toward D while executing a middle side strike to A with the right knife-hand.
- END: Bring the right foot back to a ready posture.